

Indian National Astronomy Olympiad – 2011

Question Paper

Roll Number:

INAO – 2011

Duration: **Three Hours**

Date: 29th January 2011

Maximum Marks: 100

Please Note:

- Please write your roll number on top of this page in the space provided.
- Before starting, please ensure that you have received a copy of the question paper containing total 4 pages (8 sides).
- In Section A, there are 10 multiple choice questions with 4 alternatives out of which only 1 is correct. You get 3 marks for each correct answer and **-1 mark for each wrong answer**.
- In Section B, there are 4 multiple choice questions with 4 alternatives each, out of which any number of alternatives may be correct. You get 5 marks for each correct answer. No marks are deducted for any wrong answers. **You will get credit for the question if and only if you mark all correct choices and no wrong choices**. There is no partial credit.
- For both these sections, you have to indicate the answers on the page 2 of the answer sheet by putting a × in the appropriate box against the relevant question number, like this:

Q.NO.	(a)	(b)	(c)	(d)	Q.NO.	(a)	(b)	(c)	(d)
22	<input type="checkbox"/>	<input checked="" type="checkbox"/>	<input type="checkbox"/>	<input type="checkbox"/>	35	<input checked="" type="checkbox"/>	<input checked="" type="checkbox"/>	<input type="checkbox"/>	<input type="checkbox"/>

Marking a cross (×) means affirmative response (selecting the particular choice). Do not use ticks or any other signs to mark the correct answers.

- In Section C, there are 6 analytical questions totaling 50 marks.
- Blank spaces are provided in the question paper for the rough work. No rough work should be done on the answer-sheet.
- No computational aides like calculators, log tables, slide rule etc. are allowed.
- **The answer-sheet must be returned to the invigilator**. You can take this question booklet back with you.

HOMI BHABHA CENTRE FOR SCIENCE EDUCATION

Tata Institute of Fundamental Research

V. N. Purav Marg, Mankhurd, Mumbai, 400 088

Useful Physical Constants

Radius of the Earth	$R_E \approx 6.4 \times 10^6 \text{ m}$
Mass of the Sun	$M_\odot \approx 2 \times 10^{30} \text{ kg}$
Radius of the Sun	$R_\odot \approx 7 \times 10^8 \text{ m}$
Speed of Light	$c \approx 3 \times 10^8 \text{ m/s}$
Gravitational Constant	$G \approx 6.67 \times 10^{-11} \text{ m}^3/(\text{Kg s}^2)$
Inclination of the Earth's Axis	$\epsilon \approx 23.5^\circ$
Gravitational acceleration	$g \approx 10 \text{ m/s}^2$
Reduced Planck constant	$\hbar = \frac{h}{2\pi} \approx 10^{-34} \text{ J.s}$
Avogadro constant	$N_a \approx 6.023 \times 10^{23} \text{ mol}^{-1}$
Atomic mass of Hydrogen	$M_H \approx 1.008 \text{ a.m.u.}$

Space for Rough Work

Section 1: Multiple Choice Questions

Part A: (10 Q × 3 marks each)

1. On one starry evening, Nidhi was trying to spot an artificial polar satellite from her backyard. Typical altitude of any polar satellite is about 800km above surface of the earth. What is the typical duration after sunset for which Nidhi should try her luck?
 A. 63 min **B. 109 min** C. 127 min D. 171 min

Solution:

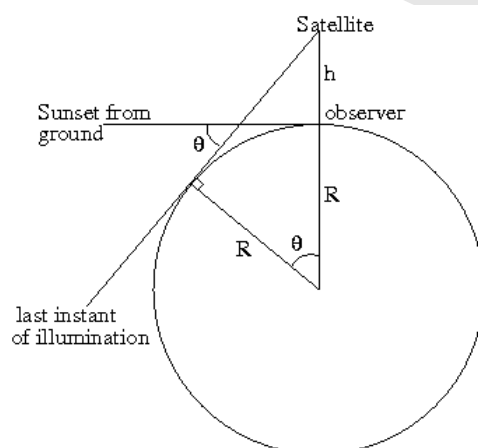

Height of the orbit of polar satellite is 800 Km. After Sunset, the Sunlight will reach satellite for a time (θ/ω) , where ω is the angular velocity of the earth and θ is as shown in the diagram.

$$\omega = 15 \text{ deg/hr}$$

$$\theta = \cos^{-1} \left(\frac{R}{R+h} \right)$$

$$\therefore \theta = \cos^{-1} \left(\frac{6.4 \times 10^6}{6.4 \times 10^6 + 8 \times 10^5} \right)$$

$$\therefore \theta = \cos^{-1} \left(\frac{8}{9} \right) = \cos^{-1}(0.889)$$

$$\theta \approx \cos^{-1}(0.866) = \cos^{-1} \left(\frac{\sqrt{3}}{2} \right) = 30^\circ$$

Thus the angle is slightly less than 30° . Thus for this angle, time will be slightly less than 2 hours.

2. What will be the difference in potential energy (ΔU) of an object of mass 'M', if it is lifted from the ground to a height of $2R$, where R is the radius of the earth?
 A. $\frac{2GM}{R}$ **B. $\frac{2GM}{3R}$** C. $\frac{GM}{2R}$ D. $\frac{GM}{3R}$

Solution: Let U_1 be the potential energy of the object on the ground, U_2 be the potential energy at the height $2R$ and ΔU be the change in the potential energy

$$\begin{aligned}
 U_1 &= \left(-\frac{GM}{R} \right) \\
 U_2 &= \left(-\frac{GM}{3R} \right) \\
 \therefore \Delta U &= U_2 - U_1 \\
 \therefore \Delta U &= -\left(\frac{GM}{3R} \right) + \left(\frac{GM}{R} \right) \\
 \therefore \Delta U &= \left(\frac{2GM}{3R} \right)
 \end{aligned}$$

Note: Implicit assumption is that the mass is scaled in earth mass units. Since the assumption was not explicitly stated, the question was deemed ambiguous and was dropped from evaluation.

3. Pole star appears stationary because.....
- A. Earth is not moving with respect to the pole star.
 - B. Earth is on the axis of rotation of the pole star.
 - C. Both Earth and the pole star have same velocity in the Milky Way galaxy.
 - D. None of the above.**

Solution: Pole star appears stationary because it is almost along the axis of rotation of the earth.

4. Consider a system of two converging lenses, one with focal length of 20cm and the other with focal length of 5cm, kept 50cm apart. An object is kept at 40cm from the first lens. What can be said about the image formed on the other side of the second lens?
- A. Erect and Real**
 - B. Inverted and Real
 - C. Erect and Virtual
 - D. Inverted and Virtual

Solution: If the object is kept at a distance of $2f$, image will also form at the distance of $2f$ and that will be real and inverted. The distance between two lenses is arranged in such a way that the image from the first lens forms at $2f$ of the second lens.

Thus again a real image of this image will be formed at distance $2f$ on the other side of second lens and it will invert the inverted image. Thus, final image will be an erect one.

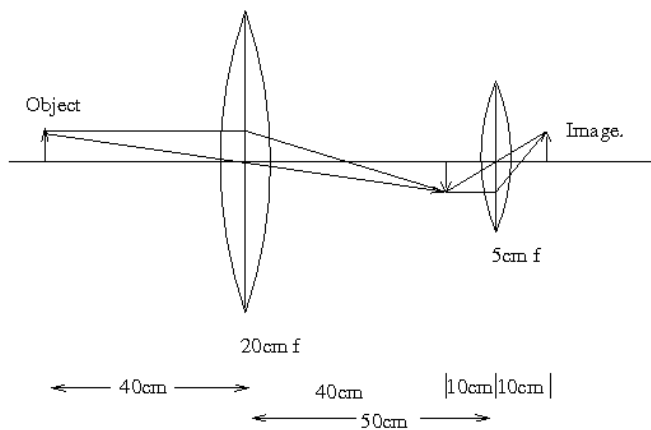

5. Three rings of same dimensions, are dropped at the same time over identical cylindrical magnets as shown below. The inner diameter of each ring is greater than the diameter of the magnet.

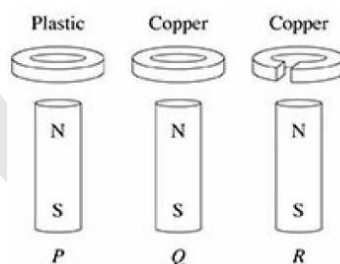

Which of the following correctly describes the order in which the rings P, Q and R reach the bottom of the respective magnets?

- A. They arrive in the order P, Q, R
- B. They arrive in the order P, R, Q**
- C. Rings P and R arrive simultaneously, followed by Q.
- D. Rings Q and R arrive simultaneously, followed by P.

Solution: Plastic is not a conducting material so its motion will not be affected. When ring Q will drop over the magnet, due to mutual induction eddy currents will form which oppose the downward motion of copper ring so it will take longer time to reach at bottom of magnet. Since R is not complete circular ring, circuit can not be completed but small local loops of eddy current still form in the ring so it will reach to bottom of magnet after ring P but before ring Q.

6. A charged particle with initial velocity \vec{V} enters a region with a uniform magnetic field $\vec{B} = B\hat{i}$. If it starts moving along the positive X-axis in a helical path such that the separation between successive loops is constant, what can be inferred about \vec{V} ?
- A. $\vec{V} = V\hat{j}$
 B. $\vec{V} = -V\hat{k}$
 C. $\vec{V} = V_y\hat{j} + V_z\hat{k}$
 D. None of the above

Solution: Lorentz's force is given by $\vec{F} = q(\vec{V} \times \vec{B})$

If initial velocity vector is restricted to only the plane perpendicular to \vec{B} , particle would have only circular motion since particle is also progressing along X-axis it must have parallel component along this direction. So initial velocity should be

$\vec{V} = V_x\hat{i} + V_y\hat{j} + V_z\hat{k}$, where

$V_x \neq 0$ and at least one out of V_y and $V_z \neq 0$

7. If $PQRS \times 4 = SRQP$, where P, Q, R and S are distinct non-zero digits. what is value of R ?
- A. 1 B. 3 C. 5 D. 7

Solution: P should be even and $4P < 10$, hence $P = 2$.

$\Rightarrow S$ is 3 or 8 and $4P \leq S$

$\Rightarrow S = 8$

$\Rightarrow Q$ and R are odd and $4Q < 10$

$\Rightarrow Q = 1$

$\Rightarrow R = 7$

8. From the given P-V diagram, find out the total work done by the gas, while going from state A to state C.

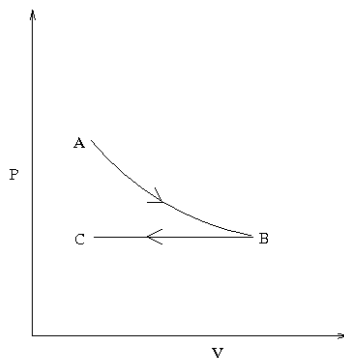

- A. $W_{tot} = W_{AC}$
 B. $W_{tot} = W_{BC} - W_{AB}$

C. $W_{tot} = W_{AB} + W_{BC}$

D. $W_{tot} = W_{AB} - W_{BC}$

Solution: From P-V diagram

Work done is = Area under the curve

\therefore Total work done by the gas = $W_{tot} = W_{AB} + W_{BC}$

The work done would be difference in the areas under the curve. However, in case of work done, the negative sign is implicit in W_{BC} .

9. Find out the equivalent resistance at AB from given circuit, if $R=10\Omega$

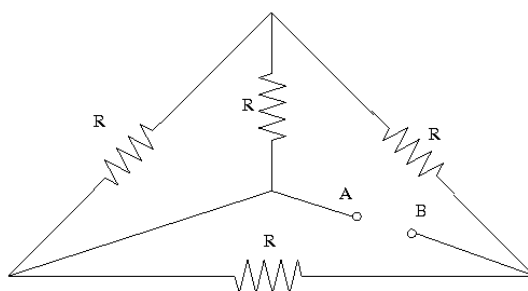

- A. 10Ω B. 100Ω C. 5Ω D. 6Ω

Solution: We can simplify given circuit as follows

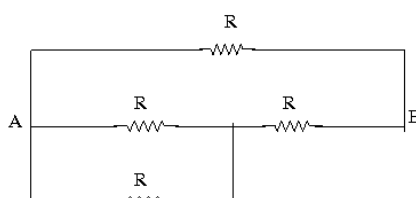

$\therefore R_{res} = 6\Omega$

10. How many 3 digit prime numbers can be formed, using digits 5, 6 and 7? Repetition of digits is allowed.
A. 20 B. 4 C. 7 D. 6

Solution: since we want it to be a prime number, last digit must be 7.

Also one can repeat same digits. Hence, there are 9 possibilities:

557, 567, 577, 657, 667, 677, 757, 767, 777

Since $5 + 6 + 7 = 18$, 567 and 657 both numbers are divisible by 3.

Clearly 777 is divisible by 7, so we have to check remaining 6 numbers out of which 667 is divisible by 23 and 767 is divisible by 13. Remaining 4 are prime numbers.

Section B: (4 questions \times 5 marks each)

11. Four conducting plates A,B,C,D are arranged as shown in the figure. Plates A and C are connected to the positive terminal of a DC source and the Plates B and D are connected to the negative terminal of a DC source. A proton is kept, at the centre of this assembly. If we disturb the proton slightly from its equilibrium position, which of the following statements will describe the path followed by the proton.

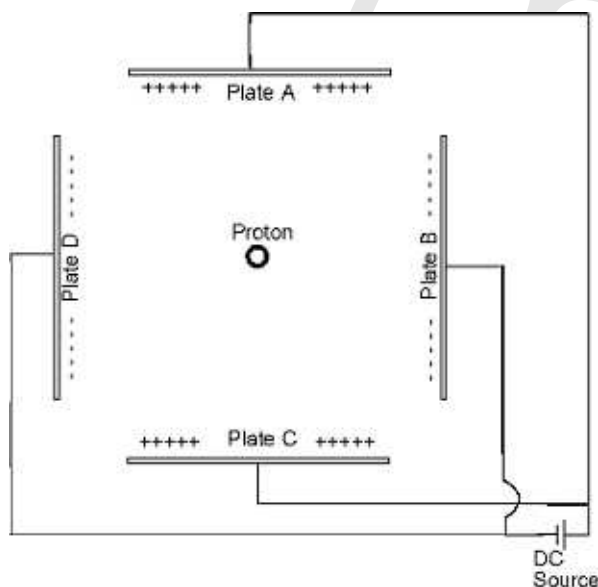

- A. If the proton is displaced slightly towards plate A, it will keep moving towards plate A.
- B. If the proton is displaced slightly towards plate D, it will keep moving towards plate D.**
- C. If the proton is displaced slightly along diagonal of the assembly between plates B and C, it will move directly towards plate B.
- D. If the proton is displaced slightly towards plate C, it will come back to its original position.**

Solution: The proton plate A and plate C are positively charged, hence if the proton is displaced towards plate A, then it will get repelled and return to its equilibrium position i.e. the centre of the assembly. Conversely, plate B and plate D are negatively charged, so if the proton is displaced towards them it will get attracted. Now if the proton is displaced diagonally, positive plates will repel it and negative plates will attract it. Thus it will move towards the closer negative plate. However, the motion will also have a harmonic oscillator component in direction of positive plates hence the overall motion may not be termed as “direct”.

12. A solid copper sphere is kept on an insulating stand. A charge given to it gets distributed uniformly on its surface only. Which of the following factors is/are relevant to this observation?

- A. Copper is a conducting material.
- B. Shape of the conductor is a sphere.
- C. Like charges repel each other.
- D. Potential energy of the system is minimum in this configuration.

Solution: In a perfect conductor, like charges are free to take up equilibrium positions in response to the Coulomb repulsion between them. Sphere being symmetric, there will not be any accumulation of charges at any point and hence there will be uniform distribution over the surface of the sphere, This is the energetically most favorable distribution of the charge. Hence the potential energy will be minimum in this case. Since the material of the sphere is a good conductor, all charges will only reside on the outer surface, whether the interior is hollow or solid.

13. A block of mass 5 kg is initially at rest on a rough horizontal surface having coefficient of static friction $\mu_s = 0.5$ and coefficient of kinetic friction $\mu_k = 0.3$. A gradually increasing horizontal force is applied for dragging it. Assuming $g = 10 \text{ m/s}^2$, acceleration of the block and dragging force acting on the block could be respectively given by,
- A. $7 \text{ m/s}^2, 50 \text{ N}$ B. $2 \text{ m/s}^2, 25 \text{ N}$ C. $0 \text{ m/s}^2, 20 \text{ N}$ D. $3 \text{ m/s}^2, 40 \text{ N}$

Solution: Initially the mass is stationary therefore, the frictional force acting on it is $F_s = \mu_s mg$ i.e. 25 N.

\therefore if the external horizontal force applied is smaller than F_s , then the acceleration produced is zero. Hence, choice 3 i.e. 0, 20 is correct.

Similarly, if the applied horizontal force is greater than the frictional force then the acceleration produced can be calculated as follows:

$$ma = F_h - F_k$$

For $F_h = 50\text{N}$, $a = 7\text{m/s}^2$
 For $F_h = 40\text{N}$, $a = 5\text{m/s}^2$

Now at exactly $F_h = 25\text{N}$, we have to consider μ_s and not μ_k .
 $\therefore a = 0\text{m/s}^2$

14. Two stars are seen close to each other in the sky. Star A appears brighter than Star B. Which of the following statements satisfactorily explain the difference in their observed brightness? Assume both the stars to be perfect black bodies.
- A. Both the stars are identical except for the fact that star A is closer to us than star B.
 - B. Both the stars are at same distance, but star A appears yellow, where as star B appears orange.

- C. Both the stars are identical except for the fact that star A has smaller radius than star B.
- D. Both the stars are identical except for the fact that star A is less massive than star B.

Solution: If both the stars are identical in mass and age, and if star A is closer to us than star B, then its apparent brightness will be greater than star B. Now if both the stars are at same distance and have same mass, then star A will appear brighter if it is intrinsically bright i.e. it is hotter (blue is hotter than yellow) than star B. the size and the mass of the star does not explicitly explain the brightness of a star. A star B having smaller radius than star A does not specify that star B will be brighter than star A. Similarly a more massive star need not always be brighter than a low mass star.

Section C: Analytical Questions

- α. (8 marks) In the following table, the first column gives the names of various bright stars in the sky and the top row gives the names of some zodiacal constellations. In the answers sheet, tick mark the constellation to which they **may** belong. Wrong tick marks carry negative points.

Star Name	Aries	Taurus	Gemini	Leo	Virgo	Scorpio
Aldebaran						
Antares						
Castor						
Denebola						
Hamal						
Pollux						
Regulus						
Sirius						
Spica						

Solution:

Star Name	Aries	Taurus	Gemini	Leo	Virgo	Scorpio
Aldebaran		✓				
Antares						✓
Castor			✓			
Denebola				✓		
Hamal	✓					
Regulus				✓		
Sirius						
Spica					✓	
Pollux			✓			

Marking scheme:

- One mark for each correct answer.
- -0.5 for each wrong answer.
- Sirius should be left blank. No marks for leaving it blank. Negative marks for putting a tick mark in that row.
- If more than one constellations are ticked for same star, it is counted as wrong answer.
- total 8 marks.

β . (8 marks) Prof. Subramaniam Chandrasekhar was first to suggest that the white dwarf stars will have an upper limit on their mass, which is given by

$$M_{limit} = k\sqrt{a\pi} \left(\frac{\hbar c}{G}\right)^b \left(\frac{1}{\mu_e m_H}\right)^2$$

where ‘ a ’, ‘ μ_e ’ and ‘ k ’ are dimensionless integers, with $k \approx 1$ and $\mu_e \approx 2$ is called mean number of nucleons per electron. m_H is the mass of one hydrogen atom. This is famously known as ‘Chandrasekhar Mass Limit’ for which he won Nobel Prize in 1983. Find ‘ a ’ and ‘ b ’.

Solution: ‘ b ’ can be found by dimensional analysis as follows (**3 marks for getting correct b**)

$$1.44M_{\odot} = k\sqrt{a\pi} \left(\frac{\hbar c}{G}\right)^b \left(\frac{1}{\mu_e m_H}\right)^2$$

$$kg = \left(\frac{J \cdot s \times m/s}{\frac{Nm^2}{kg^2}}\right)^b \frac{1}{(kg)^2}$$

$$\text{now, } N = \frac{kg \cdot m}{s^2} \text{ and } J = \frac{kg \cdot m^2}{s^2}$$

$$\therefore kg = \left(\frac{\frac{m^2 \cdot kg}{s^2} \cdot s \times m/s}{\frac{\frac{kg \cdot m}{s^2} \cdot m^2}{kg^2}}\right)^b \frac{1}{(kg^2)^2}$$

$$\Rightarrow b = 3/2$$

Similarly ‘ a ’ can be found by substituting the values of all the constants given

and equating it to $1.44M_{\odot}$, which is the famous Chandrasekhar mass limit.

$$\begin{aligned}
 1.44 \times 2 \times 10^{30} &= \sqrt{a\pi} \left(\frac{10^{-34} \times 3 \times 10^8}{6.67 \times 10^{-11}} \right)^{3/2} \left(\frac{6.023 \times 10^{26}}{2 \times 1.008} \right)^2 \quad (1\text{mark}) \\
 &= \sqrt{a\pi} \left(\frac{1}{2.22 \times 10^{15}} \right)^{3/2} \times \frac{36 \times 10^{52}}{4} \\
 \sqrt{a\pi} &\approx \frac{1.44 \times 2 \times 10^{30} \times (2.22 \times 10^{15})^{3/2}}{9 \times 10^{52}} \\
 \sqrt{a\pi} &\approx 0.16 \times 2 \times (2.22)^{3/2} \times 10^{-22} \times 10^{22.5} \\
 \sqrt{a\pi} &\approx \sqrt{(0.32)^2 \times (2.22)^3 \times 10} \\
 \sqrt{a\pi} &\approx \sqrt{0.1024 \times 10.7 \times 10} \\
 a\pi &\approx 10.9 \\
 a &\approx 3.47 \\
 \Rightarrow a &\approx 3
 \end{aligned}$$

Marking scheme:

- All 4 marks for getting correct answer.
- 3 marks for close enough integer answers.
- 2 marks for getting only correct order of magnitude (i.e. 0).
- 0.5 marks deducted if final answer is not an integer.
- +1 mark for overall clarity of solution.

- γ . (8 marks) Hot solar plasma is emitted from surface of a circular sunspot whose diameter is 10,000 km. When the plasma reaches the height of 16,000 km above the surface of the sun its horizontal cross section is measured to have diameter of 90,000km. Assuming that the edge of the plasma cone is parabolic, find the depth inside the sun from which the plasma started. Assume that the viscosity and magnetic permeability remains same inside and outside the solar surface.

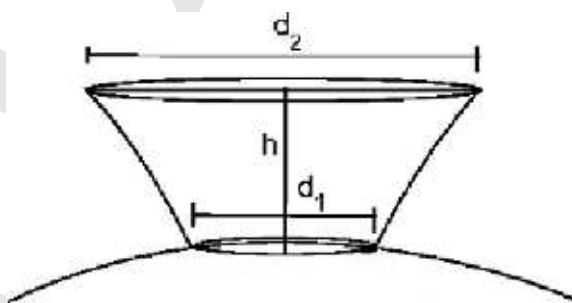

Solution:

$$\frac{d_1}{d_2} = \frac{r^2}{(r+h)^2} \quad (3\text{marks})$$

$$\therefore \frac{1}{9} = \frac{r^2}{(r+h)^2}$$

$$\therefore \frac{1}{3} = \frac{r}{(r+16000)}$$

$$\therefore r = 8000km \quad (3\text{marks})$$

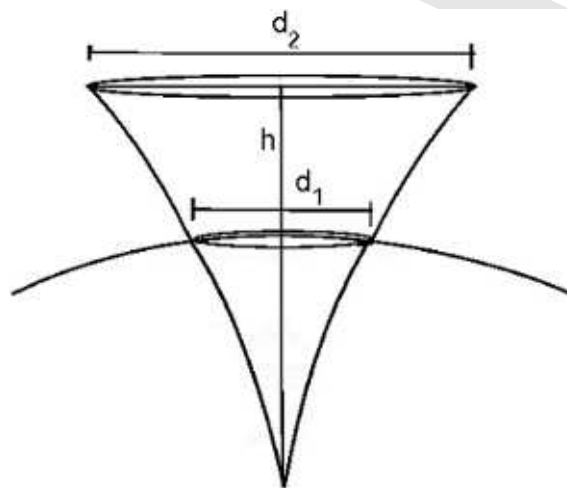

(2 marks) Marking scheme:

- Wrong parabola ($x^2 = 4ay$) considered. Deduct 4 marks.
- Linear terms in y included in the equation, grading as per merit of justification.

- δ. (8 marks) Vinita studied a star for 55 days in succession. She noted down the temperature of the star everyday, which was varying in a nice symmetric manner. The data of her observations is given below. Help Vinita to find the mean temperature and the period of temperature variation of this star by any suitable method. Give proper justification for the method used.

Days	Temperature	Days	Temperature	Days	Temperature
1	5472	20	5312	38	5437
2	5527	21	5264	39	5503
3	5550	22	5250	40	5543
4	5536	23	5273	41	5547
5	5488	24	5328	42	5516
6	5419	25	5400	43	5455
7	5345	26	5472	44	5381
8	5284	27	5527	45	5312
9	5253	28	5550	46	5264
10	5257	29	5536	47	5250
11	5297	30	5488	48	5273
12	5363	31	5419	49	5328
13	5437	32	5345	50	5400
14	5503	33	5284	51	5472
15	5543	34	5253	52	5527
16	5547	35	5257	53	5550
17	5516	36	5297	54	5536
18	5455	37	5363	55	5488
19	5381				

Solution:

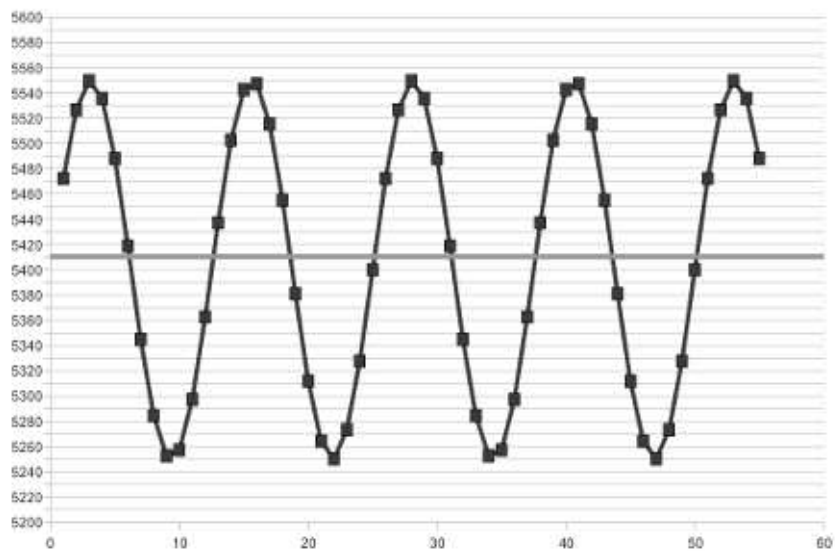

Days	Maximum values Temperature	Days	Minimum values Temperature
3	5550	9	5253
16	5547	22	5250
28	5550	34	5253
41	5547	47	5250
53	5550		

after exactly 25 days you get same maximum temperature and there is one peak in between. so the period is $25/2 = 12.5$ days.

from the data maximum ≈ 5550

minimum ≈ 5250

mean = 5400°C

since data contains some incomplete period, mean of all 55 readings will give incorrect answer. Since data is symmetric, mean by merely finding peaks and taking average is reasonably correct.

Marking Scheme:

- Period value: 2 marks
- Period justification: 1 mark
- Mean value: 2 marks
- Correct method for finding mean: 3 marks
- If graphical method is used, upto 2 marks for correct drawing of graph.
- No credit for averaging over all 55 readings.

- ε. (9 marks) On one fine day, Akshay was watching DTH television from Madurai in Tamil Nadu ($78^\circ 07' E; 9^\circ 48' N$). He got a call from his IIT friend, Sujeet, who was watching DTH television of the same company from Salem in Tamil Nadu ($78^\circ 07' E; 11^\circ 39' N$). Both were getting their DTH signals from the same satellite located at 36000 km directly above a point at the same longitude but at latitude of $10^\circ 43.5' N$. Find the angle difference in the antenna pointing for Akshay and Sujeet.

Solution:

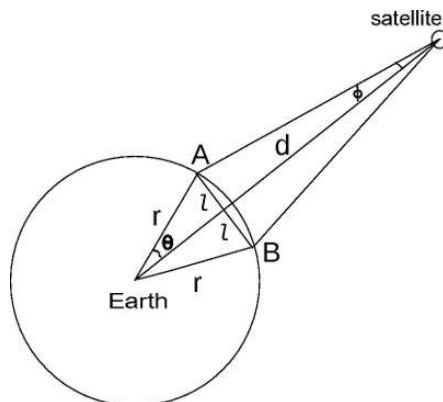

(3 marks)

Let x be the angle of the antenna with respect to horizon. Radius of the earth (r) = 6400 km.

$$\begin{aligned}
 l &\approx r\theta \approx d\phi \\
 x &\approx 90 - \phi \\
 &\approx 90 - \frac{r\theta}{d} \\
 &\approx 90 - \frac{6400}{36000} \times \frac{1.85}{2} \\
 &\approx 90 - \frac{64}{200} \times \frac{1.85}{36} \\
 &\approx 90 - 0.32 \times 0.52 \\
 &\approx 90 - \frac{1}{6}
 \end{aligned}$$

The antenna at Salem will be pointing $\frac{1}{6}^\circ$ south of local zenith and antenna at Madurai $\frac{1}{6}^\circ$ north of local zenith. The secular angle difference is $\frac{1}{3}^\circ$ or $20'$ (4 marks).

The total angle difference (i.e. difference in angles measured w.r.t. local horizons) would be $20' + 1^\circ 51' = 2^\circ 11'$ (2 marks)

ζ. Sketch the graphs of following functions in the space provided on the answersheet (Plotting on a graphsheet is not expected):

(a) (3 marks) $|x + 1| + |x - 1|$

(b) (3 marks) $x + \sin(x)$.

(c) (3 marks) $x \log(x)$.

Solution:

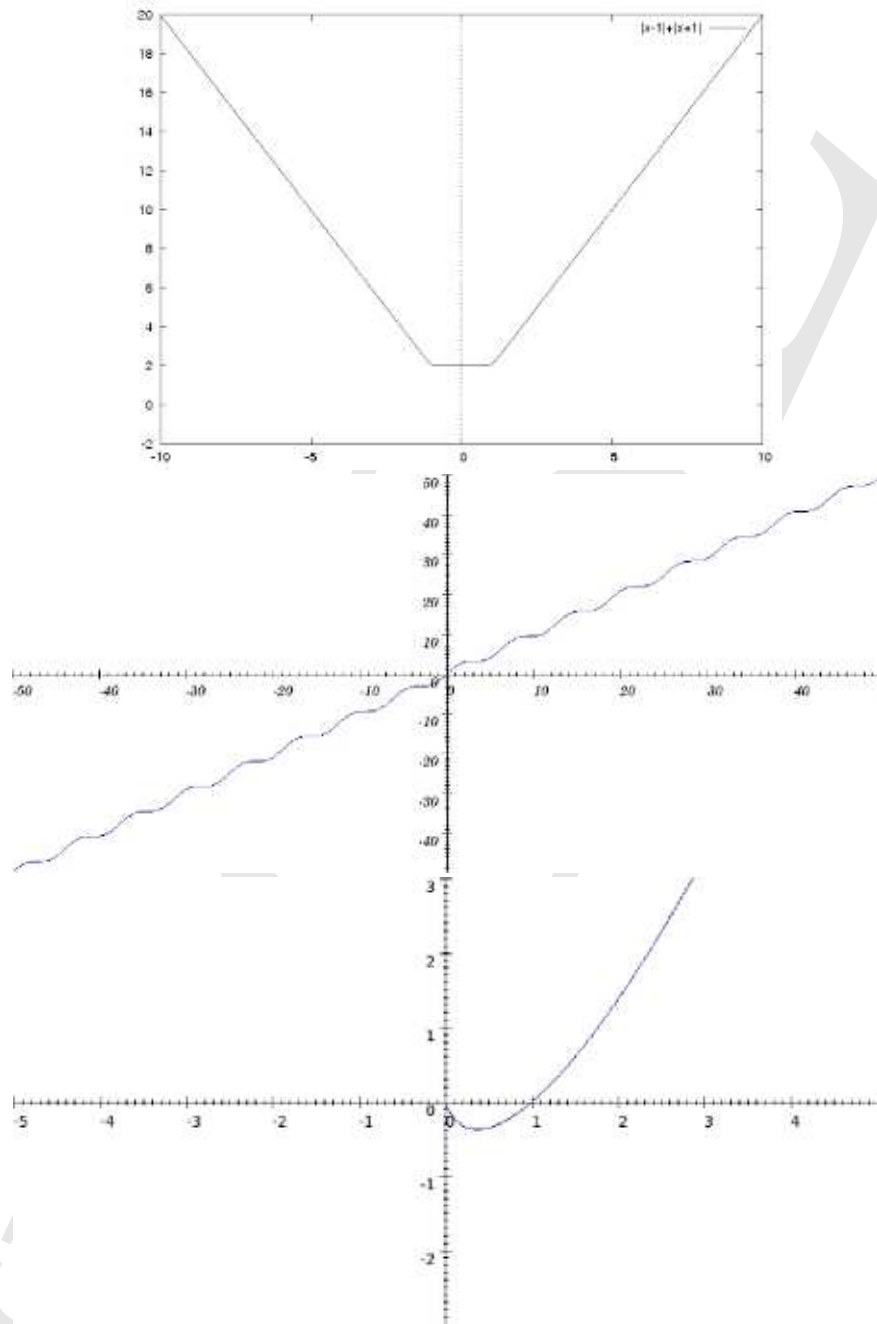

Marking scheme:

Criterion	Graph 1	Graph 2	Graph 3
Shape	1	2	1
Values	1	–	2
Slope	1	–	–
Concept	–	1	–

Space for Rough Work

HB
CSFE